

PM Series

PM CORE

CORE SHAPES AND DIMENSIONS/CHARACTERISTICS

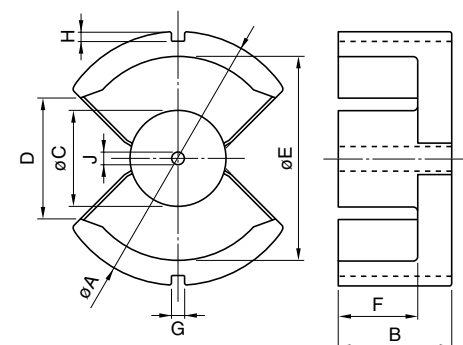

PRODUCT IDENTIFICATION

PE22	PM	111	$\times 100$
(1)	(2)	(3)	(4)

- (1) Material name
- (2) Shape
- (3) Dimension A
- (4) Dimension 2B

Part No.	AL*(nH/N ²) ±25%	Dimensions (mm)									
		øA	B×2	øC	D	øE	F×2	G	H	J	
PE22 PM111×100	12590										
PC40 PM111×100	13927	111.0±2.2	100.0±1.0	41.5±0.7	53.0±1.0	89.0±1.8	70.0±1.0	5.8±0.5	4.2±0.2	5.6±0.2	
PE90 PM111×100	13321										

* Measuring condition: T=23°C, f=1kHz, H_m=0.4A/m

Part No.	Core factor					Weight(g)
	C ₁ (mm ⁻¹)	C ₂ ×10 ⁻² (mm ⁻³)	A _e (mm ²)	ℓ _e (mm)	V _e (mm ³)	
PE22 PM111×100						2200
PC40 PM111×100	0.12573	0.0000739	1702	214	364228	2200
PE90 PM111×100						2246