

Current Sensing Metal Chip Resistor



■ Features

- SMD Type designed for automatic insertion
- High power rating in small size
- Low resistance resistor for current detection
- Metal foil construction ensures high reliability and performance with very low and stable TCR
- Designed for current sense circuits in power electronic systems
- Pb-Free to meet RoHS requirements

■ Construction

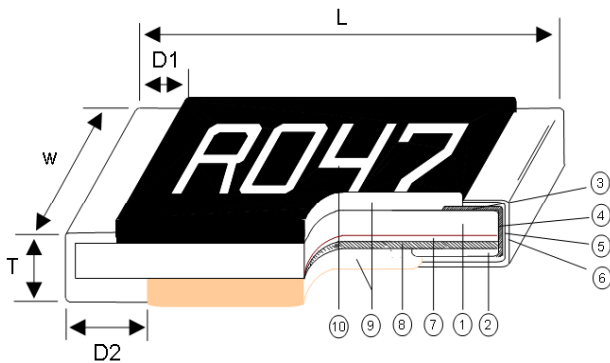

■ Applications

- Power Management Applications
- Switching Power Supply
- Over Current Protection in Audio Applications
- Voltage Regulation Module (VRM)
- DC-DC Converter, Battery Pack, Charger, Adaptor

① Alumina Substrate	⑤ Barrier Layer (Ni)	⑨ Primary Overcoat (Epoxy)
② Bottom Electrode (Cu)	⑥ External Electrode (Sn)	⑩ Marking (Epoxy)
③ Top Electrode (NiCr)	⑦ Adhesive (Acrylic)	
④ Edge Electrode (NiCr)	⑧ Resistor Layer (Alloy)	

■ Dimensions

Type	Size (Inch)	Resistance Range (mΩ)	L (mm)	W (mm)	T (mm)	D1 (mm)	D2 (mm)
CSM03	0603	10 - 29	1.55±0.10	0.85±0.10	0.40±0.10	0.30±0.15	0.45±0.15
		30 - 100	1.55±0.10	0.85±0.10	0.40±0.10	0.30±0.15	0.35±0.15
CSM05	0805	10 - 29	2.00±0.15	1.25±0.15	0.55±0.10	0.30±0.20	0.50±0.20
		30 - 100	2.00±0.15	1.25±0.15	0.52±0.10	0.30±0.20	0.35±0.20
CSM06	1206	10 - 29	3.05±0.15	1.55±0.15	0.58±0.15	0.50±0.25	0.90±0.25
		30 - 100	3.05±0.15	1.55±0.15	0.55±0.15	0.50±0.25	0.60±0.25
CSM10	2010	10 - 29	5.00±0.20	2.50±0.20	0.58±0.15	0.60±0.30	1.50±0.30
		30 - 100	5.00±0.20	2.50±0.20	0.55±0.15	0.60±0.30	0.90±0.30
CSM12	2512	10 - 29	6.30±0.20	3.15±0.20	0.58±0.15	0.60±0.30	1.80±0.30
		30 - 100	6.30±0.20	3.15±0.20	0.55±0.15	0.60±0.30	1.20±0.30

Part Numbering

CSM	06	F	T	E	U	R100	
Product Type	Dimensions (L×W)	Resistance Tolerance	Packaging Code	TCR (PPM/°C)	Power Rating	Resistance	Marking
	03: 0603 05: 0805 06: 1206 10: 2010 12: 2512	F: ±1% G: ±2% J: ±5%	T: Taping Reel B: Bulk	D: ±50 E: ±100	T: 1W Q: 3/4W U: 1/2W V: 1/4W W: 1/8W	R010: 0.01Ω R100: 0.1Ω	: Standard N: No Marking

Recommend Land Pattern

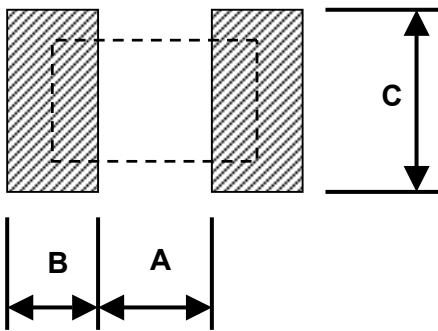

Derating Curve

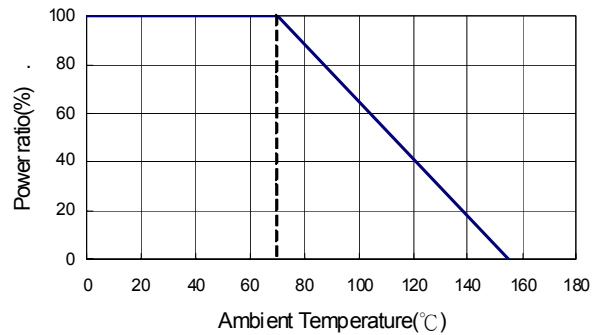

Type	Resistance Range	A (mm)	B (mm)	C (mm)
CSM03	10-29mΩ	0.40	1.20	0.9
	30-100mΩ	0.70	1.05	0.9
CSM05	10-29mΩ	0.80	1.10	1.35
	30-100mΩ	1.00	1.00	1.35
CSM06	10-29mΩ	0.9	1.70	1.70
	30-100mΩ	1.50	1.40	1.70
CSM10	10-29mΩ	1.70	2.35	2.50
	30-100mΩ	2.80	1.80	2.50
CSM12	10-29mΩ	2.30	2.90	3.10
	30-100mΩ	3.60	2.25	3.10

Marking for 0603

Type	Code
R10	0.100Ω
R01	0.010Ω
<u>101</u>	0.101Ω
<u>035</u>	0.035Ω

■ Soldering Condition

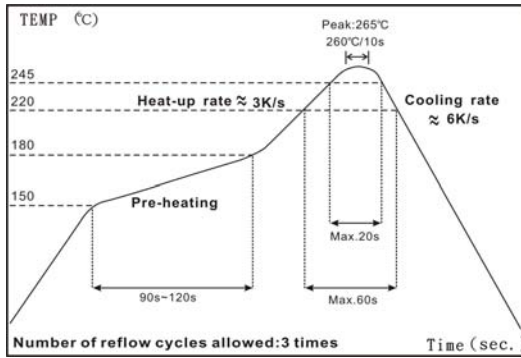

IR Reflow Soldering

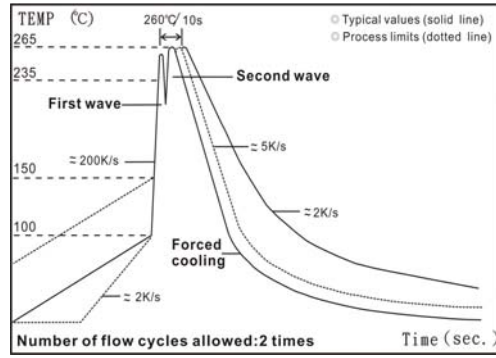

Wave Soldering (Flow Soldering)

- (1) Time of IR reflow soldering at maximum temperature point 260°C : 10s
- (2) Time of wave soldering at maximum temperature point 260°C : 10s
- (3) Time of soldering iron at maximum temperature point 410°C : 5s

■ Standard Electrical Specifications

Type \ Item	Power Rating at 70°C	Operating Temp. Range	Resistance Range (mΩ)			TCR (PPM/°C)
			±1%	±2%	±5%	
CSM03 (0603)	1/8W	-55 ~ +155°C	10 - 19			±100
			20 - 100			±50 ±100
CSM05 (0805)	1/4W		10 - 19			±100
			20 - 100			±50 ±100
CSM06 (1206)	1/2W		10 - 19			±100
			20 - 100			±50 ±100
CSM10 (2010)	3/4W		10 - 19			±100
			20 - 100			±50 ±100
CSM12 (2512)	1W	10 - 19			±100	
		20 - 100			±50 ±100	

Operating Voltage= $\sqrt{P \cdot R}$; Overload Voltage= $2.5 \cdot \sqrt{P \cdot R}$; Operating Current= $\sqrt{P/R}$

Viking is capable of manufacturing the optional spec based on customer's requirement

Environmental Characteristics

Item	Requirement	Test Method
Temperature Coefficient of Resistance (T.C.R.)	As Spec.	JIS-C-5201-1 4.8 IEC-60115-1 4.8 -55°C~+125°C, 25°C is the reference temperature
Short Time Overload	$\pm(0.5\%+0.05\Omega)$	JIS-C-5201-1 4.13 IEC-60115-1 4.13 5 X Rated Power for 5 seconds
Insulation Resistance	$\geq 10G$	JIS-C-5201-1 4.6 IEC-60115-1 4.6 Max. Overload voltage for 1 minute
Endurance	$\pm(1.0\%+0.05\Omega)$	JIS-C-5201-1 4.25 IEC-60115-1 4.25.1 70 \pm 2°C, RCWV for 1000 hrs with 1.5 hrs "ON" and 0.5 hrs "OFF"
Damp Heat with Load	$\pm(1.0\%+0.05\Omega)$	JIS-C-5201-1 4.24 40 \pm 2°C, 90~95% R.H., RCWV for 1000 hrs with 1.5 hrs "ON" and 0.5 hrs "OFF"
Dry Heat	$\pm(0.5\%+0.05\Omega)$	JIS-C-5201-1 4.23 IEC-60115-1 2.23.2 at +155°C for 1000 hrs
Bending Strength	$\pm(1.0\%+0.05\Omega)$	JIS-C-5201-1 4.33 IEC-60115-1 4.33 Bending once for 5 seconds with 3mm 2010, 2512 sizes: 2mm
Solderability	95% min. coverage	JIS-C-5201-1 4.17 IEC-60115-1 4.17 245 \pm 5°C for 3 seconds
Resistance to Soldering Heat	$\pm(0.5\%+0.05\Omega)$	JIS-C-5201-1 4.18 IEC-60115-1 4.18 260 \pm 5°C for 10 seconds
Voltage Proof	No breakdown or flashover	JIS-C-5201-1 4.7 IEC-60115-1 4.7 1.42 times Max. Operating Voltage for 1 minute
Leaching	Individual leaching area $\leq 5\%$ Total leaching area $\leq 10\%$	JIS-C-5201-1 4.18 IEC-60068-2-58 8.2.1 260 \pm 5°C for 30 seconds
Rapid Change of Temperature	$\pm(0.5\%+0.05\Omega)$	JIS-C-5201-1 4.18 IEC-60115-1 4.18 -55°C to +155°C, 5 cycles

RCWV(Rated continuous working voltage)= $\sqrt{P \cdot R}$ or Max. Operating voltage whichever is lower.

Storage Temperature: 25 \pm 3°C; Humidity < 80%RH

■Packaging

Packaging Quantity & Reel Specifications

Type	ΦA (mm)	ΦB (mm)	ΦC (mm)	W (mm)	T (mm)	Paper Tape (EA)	Emboss Plastic Tape (EA)
CSM03	178.0±1.0	60.0±1.0	13.5±0.7	9.5±0.1	11.5±1.0	5,000	-
CSM05	178.0±1.0	60.0±1.0	13.5±0.7	9.5±0.1	11.5±1.0	5,000	-
CSM06	178.0±1.0	60.0±1.0	13.5±0.7	9.5±0.1	11.5±1.0	5,000	-
CSM10	178.0±1.0	60.0±1.0	13.5±0.7	13.5±1.0	15.5±1.0	-	4,000
CSM12	178.0±1.0	60.0±1.0	13.5±0.7	13.5±1.0	15.5±1.0	-	4,000

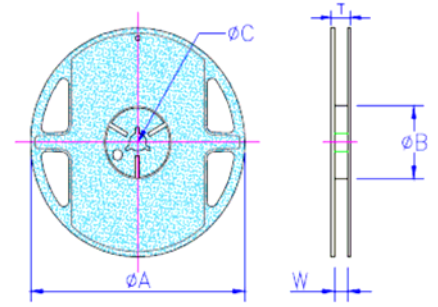

Paper Tape Specifications

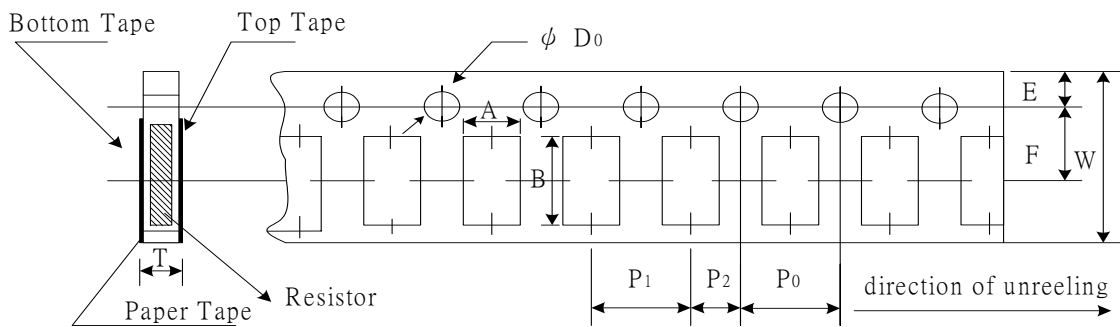

Type	A (mm)	B (mm)	W (mm)	E (mm)	F (mm)	P0 (mm)	P1 (mm)	P2 (mm)	ΦD0 (mm)	T (mm)
CSM03	1.10±0.10	1.90±0.10	8.0±0.20	1.75±0.10	3.50±0.05	4.00±0.10	4.00±0.05	2.00±0.05	1.50+0.1,-0	0.70±0.10
CSM05	1.60±0.10	2.40±0.20	8.0±0.20	1.75±0.10	3.50±0.05	4.00±0.10	4.00±0.05	2.00±0.05	1.50+0.1,-0	0.85±0.10
CSM06	1.90±0.10	3.50±0.20	8.0±0.20	1.75±0.10	3.50±0.05	4.00±0.10	4.00±0.05	2.00±0.05	1.50+0.1,-0	0.85±0.10

Emboss Plastic Tape Specifications

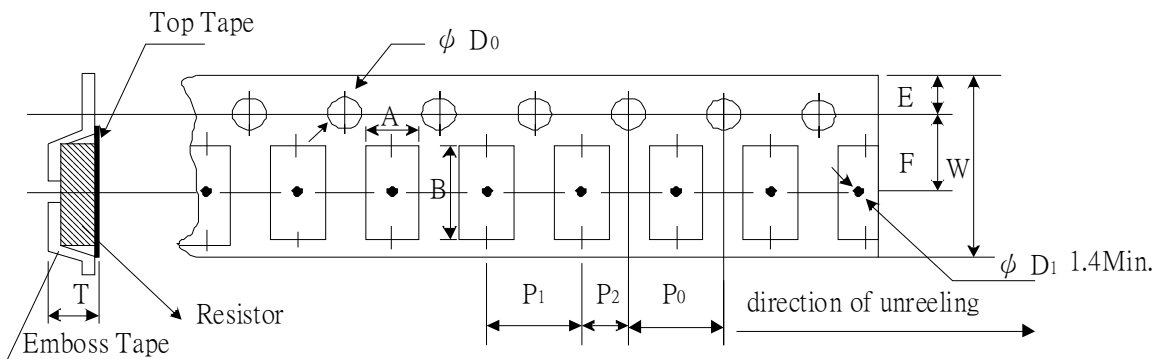

Type	A (mm)	B (mm)	W (mm)	E (mm)	F (mm)	P0 (mm)	P1 (mm)	P2 (mm)	ΦD0 (mm)	T (mm)
CSM10	2.80±0.10	5.50±0.10	12.0±0.30	1.75±0.10	5.5±0.05	4.00±0.05	4.00±0.10	2.00±0.05	1.50+0.10	1.00±0.20
CSM12	3.50±0.10	6.70±0.10	12.0±0.30	1.75±0.10	5.5±0.05	4.00±0.05	4.00±0.10	2.00±0.05	1.50+0.10	1.00±0.20