

Ultra-Low Chip Resistor Jumper
Ultra-Low Chip Resistor Jumper - LRJ Series

■ Features

- Ultra-Low resistance values Max. 0.5 mΩ
- High current application
- Pb Free

■ Applications

- NB
- Mobil Device
- Server
- Electrical tools
- Power Management



■ Construction

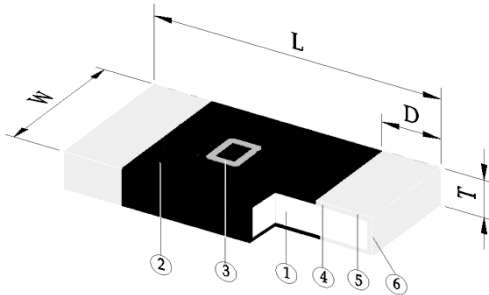

LRJ06/LRJ10/LRJ12

① Alloy Plate	④ Internal Electrode
② Overcoat	⑤ Barrier Layer
③ Marking	⑥ Solder Plating

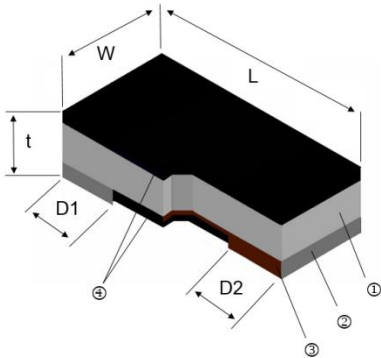

LRJ02/LRJ03/LRJ05

① Alumina Substrate	④ Overcoat
② External Electrode	No Marking
③ Resistor Layer	

■ Dimensions

Type	Size (Inch)	L (mm)	W (mm)	T (mm)	D (mm)
LRJ02	0402	1.00±0.05	0.50±0.05	0.25±0.10	0.30±0.10
LRJ03	0603	1.50±0.15	0.80±0.15	0.42±0.10	0.40±0.10
LRJ05	0805	1.95±0.15	1.20±0.15	0.58±0.10	0.55±0.10
LRJ06	1206	3.10±0.20	1.45±0.20	0.45±0.20	0.55±0.20
LRJ10	2010	4.85±0.20	2.50±0.20	0.45±0.20	0.75±0.20
LRJ12	2512	6.20±0.20	3.20±0.20	0.60±0.20	0.90±0.20

Derating Curve

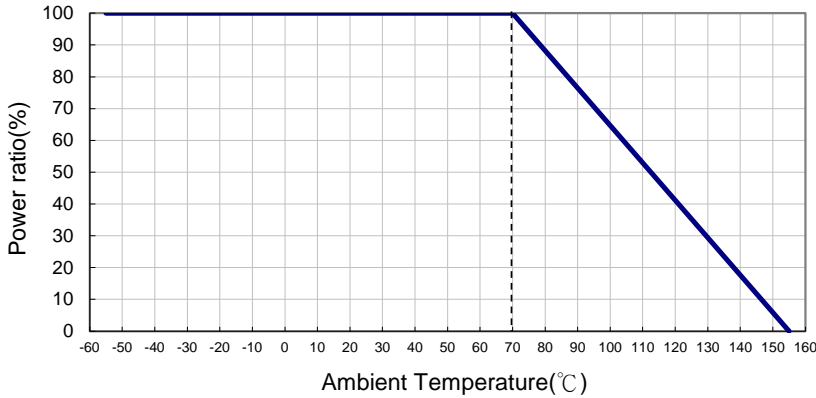

Part Numbering

LRJ	10	-	T	-		R0R0
Product Type	Dimensions (LxW)	Resistance Tolerance	Packaging Code	TCR (PPM/°C)	Power Rating	Resistance
	02: 0402 03: 0603 05: 0805 06: 1206 10: 2010 12: 2512	- No Specified	T: Taping Reel	- No Specified	: Standard	R0R0: Jumper

Standard Electrical Specifications

Item Type	Operating Temp. Range	Resistance Range (mΩ)	Rated Current (A)
LRJ02 (0402)	-55 ~ +155°C	0.5 mΩ Max.	20
LRJ03(0603)	-55 ~ +155°C		22.4
LRJ05(0805)	-55 ~ +155°C		31.6
LRJ06 (1206)	-55 ~ +155°C	0.2 mΩ Max.	50
LRJ10 (2010)	-55 ~ +155°C		71
LRJ12 (2512)	-55 ~ +155°C		100

Soldering Condition (Reflow Soldering Only)

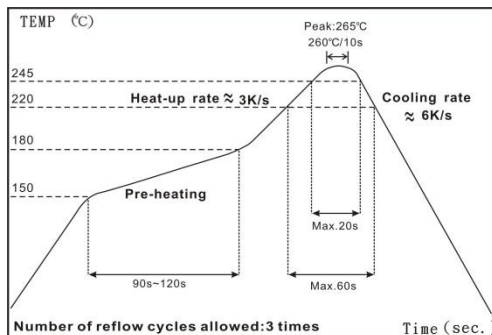

Time of IR reflow soldering at maximum temperature point 260°C : 10s

Notice : Wave soldering and hand soldering are not available.

Environmental Characteristics

Item	Requirement	Test Method
Variation of resistance with temperature	Max. 0.5 mΩ	JIS-C-5201-1 4.8 IEC-60115-1 4.8 +25/-55°C, +25/+125°C
Short Time Overload	Max. 0.5 mΩ	JIS-C-5201-1 4.13 IEC-60115-1 4.13 Rated current*1.5 for 2s(LRJ02/06/10/12) Rated current*2.5 for 5s(LRJ03/05)
Endurance	Max. 0.5 mΩ	JIS-C-5201-1 4.25 IEC-60115-1 4.25.1 70±2°C, Rated current for 1000 hrs with 1.5 hrs "ON" and 0.5 hrs "OFF"
Damp Heat	Max. 0.5 mΩ	JIS-C-5201-1 4.24 40±2°C, 90~95% R.H. for 1000 hrs.
Dry Heat	Max. 0.5 mΩ	JIS-C-5201-1 4.23 IEC-60115-1 2.23.2 at +155°C for 1000 hrs
Bending Strength	Max. 0.5 mΩ	JIS-C-5201-1 4.33 IEC-60115-1 4.33 Bending once for 60 seconds with 3mm
Solderability	95% min. coverage	JIS-C-5201-1 4.17 IEC-60115-1 4.17 245±5°C for 3 seconds
Resistance to Soldering Heat	Max. 0.5 mΩ	JIS-C-5201-1 4.18 IEC-60115-1 4.18 260±5°C for 10 seconds
Rapid Change of Temperature	Max. 0.5 mΩ	JIS-C-5201-1 4.18 IEC-60115-1 4.18 -55°C to +125°C, 5 cycles

RCWV(Rated Continuous Working Voltage)= $\sqrt{P \cdot R}$ or Max. Operating Voltage whichever is lower

Operating Current = $\sqrt{P/R}$, Operating Voltage = $\sqrt{P \cdot R}$

Storage Temperature: 15~28°C; Humidity < 80%RH

Shelf Life: 2 years from production date.

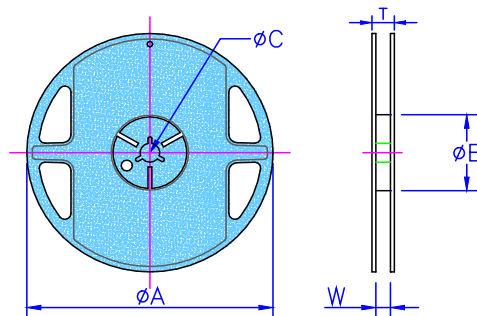

Packaging

Reel Specifications & Packaging Quantity

Type	Packaging Quantity		Tape Width	Reel Diameter	ΦA (mm)	ΦB (mm)	ΦC (mm)	W (mm)	T (mm)
LRJ02	Paper	10K	8mm	7inch	178±1.0	60.0±1.0	13.5±0.7	9.5±1.0	11.5 ± 1.0
LRJ03	Paper	5K	8mm	7inch	178±1.0	60.0±1.0	13.5±0.7	9.5±1.0	11.5 ± 1.0
LRJ05	Paper	5K	8mm	7inch	178±1.0	60.0±1.0	13.5±0.7	9.5±1.0	11.5 ± 1.0
LRJ06	Paper	5K	8mm	7 inch	178.5±1.5	60 ^{+1/-0}	13.0±0.2	9.0±0.5	12.5±0.5
LRJ10	Embossed	4K	12mm	7 inch	178.5±1.5	60 ^{+1/-0}	13.0±0.5	13.0±0.5	15.5±0.5
LRJ12	Embossed	4K	12mm	7 inch	178.5±1.5	60±1.0	13.0±0.5	13.0±1.0	15.5±0.5

Paper Tape Specifications

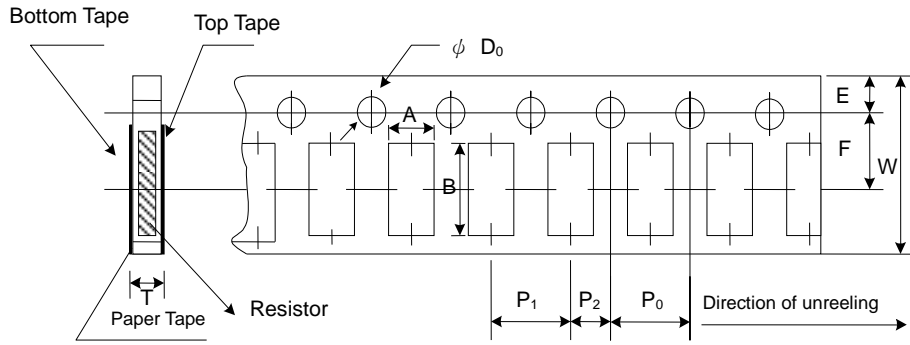

Type	A (mm)	B (mm)	W (mm)	E (mm)	F (mm)	P ₀ (mm)	P ₁ (mm)	P ₂ (mm)	ΦD ₀ (mm)	T (mm)
LRJ02	0.70±0.05	1.16±0.05	8.00±0.10	1.75±0.05	3.50±0.05	4.00±0.10	2.00±0.05	2.00±0.05	1.55±0.05	0.45±0.10
LRJ03	1.10±0.05	1.90±0.05	8.00±0.10	1.75±0.05	3.50±0.05	4.00±0.10	4.00±0.10	2.00±0.05	1.55±0.05	0.60±0.03
LRJ05	1.63±0.05	2.4±0.05	8.00±0.10	1.75±0.05	3.50±0.05	4.00±0.10	4.00±0.10	2.00±0.05	1.55±0.05	0.75±0.05
LRJ06	1.90±0.15	3.50±0.20	8.00±0.20	1.75±0.10	3.50±0.05	4.00±0.10	4.00±0.05	2.00±0.05	1.50+0.1/-0	0.85±0.10

Embossed Plastic Tape Specifications

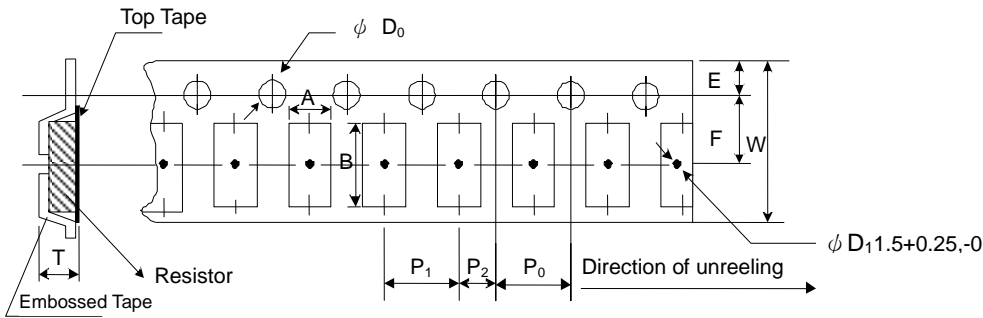

Type	A (mm)	B (mm)	W (mm)	E (mm)	F (mm)	P ₀ (mm)	P ₁ (mm)	P ₂ (mm)	ΦD ₀ (mm)	T (mm)
LRJ10	2.80±0.10	5.40±0.20	12.0±0.30	1.75±0.10	5.5±0.05	4.00±0.10	4.00±0.10	2.00±0.05	1.50+0.1, -0	1.2 ⁺⁰
LRJ12	3.50±0.10	6.70±0.10	12.0±0.30	1.75±0.10	5.5±0.05	4.00±0.10	4.00±0.10	2.00±0.05	1.50+0.1/-0	1.20+0

Recommend Land Pattern

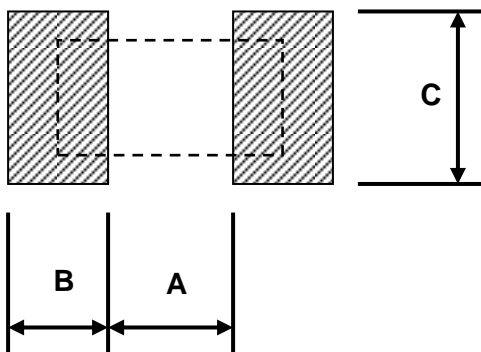

Type	A (mm)	B (mm)	C (mm)
LRJ02	0.50	0.65	0.50
LRJ03	0.50	1.00	0.90
LRJ05	0.80	1.30	1.30
LRJ06	2.00	0.90	1.60
LRJ10	3.80	0.90	2.80
LRJ12	4.00	2.00	3.50